

**1. MP35 Absolute encoder (Through shaft)**

**1.1 Introduction**

MP35 is an ultra-thin, micro-compact, mechanical flexible connection design with high precision absolute optical encoder, capable of outputting 24Bits of single-turn position information. The product is compact, highly integrated and easy to install, which can solve the installation problems in limited space.

MP35-E

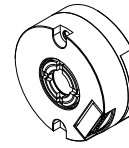

**1.2 Feature:**

- External diameter Ø35mm, Thickness 15mm, Hollow shaft up to Ø8mm;
- Concentric shaft ring locking structure;
- Adopt non-contact photoelectric reflective principle;
- Interface: BISS\_C or SSI;
- Accuracy: ±80";
- Resolution up to 24Bits;

MP35-J

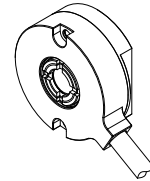

**1.3 Application:**

Servo motor, robot and other industrial automations.

**1.4 Connection:**

Radial socket (8P SM08B-GHS-TB).  
Radial cable (length 1000mm).

**1.5 Protection:**

IP50

**1.6 Weight:**

about 70g

**2. Model guide**

Model form (filled required parameters in the box as following)

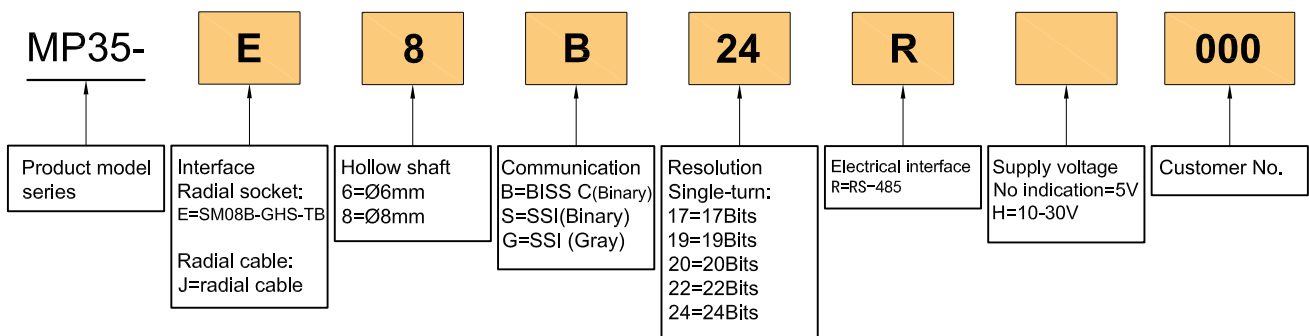

### 3. Basic specification

#### 3.1 Resolution

Single-turn(ST)		
17Bits	$2^{17}(0\sim+131071)$	Under 24Bits as standard, expandable up to Max 32Bits
19Bits	$2^{19}(0\sim+524287)$	
20Bits	$2^{20}(0\sim+1048575)$	
22Bits	$2^{22}(0\sim+4194303)$	
24Bits	$2^{24}(0\sim+16777215)$	

#### 3.2 Parameter

Name	Parameter	Remark
Scanning principle	Photoelectric	
Accuracy	$\pm 80''$	
Response speed	Normal action: $6000\text{min}^{-1}$	
RMS position signal noise	$\pm 2 @ 18 \text{ Bits/r}$	
Communication	BiSS_C (Binary)	Pls refer to BiSS_C standards
	SSI (Binary / Gray code)	Pls refer to SSI standards
Communication clock frequency	$\leq 10 \text{ MHz(BiSS)}$ or $\leq 5 \text{ MHz(SSI)}$	
Max resolution	24 Bits expandable up to Max 32 Bits	For frame infomation,please refer to P9 & P10 (data frammes)
Starting time	Typical value: 13 ms	
Absolute position sampling period	$\leq 75 \text{ ns}$	
Allowable speed	$\leq 32200 \text{ r/min}$	Restricted by mechanical speed limit
Electrical connection	Radial socket & Radial cable	Pls refer to page 6、 7
Cable	Twisted-paired cable	
Cable length	200mm - 10000mm	
Internal single-turn position update rate	15000kHz	Access rate is limited by communication frequency
Internal multi-turn position update rate	11.5kHz	
Temperature alarm limit value	$-20^{\circ}\text{C}\sim 95^{\circ}\text{C}$	

## 3.3 Mechanical specification

Name	Parameter	Remark
Mechanical Connection	Ring-locked to the shaft, steel connection fixed to the motor platform	
Diameter of shaft	Ø6mm、Ø8mm (through)	Pls refer to page 5 for dimensions
Shaft material	Stainless steel	
Starting Torque	less than $5 \times 10^{-3}$ N·m	
Inertia Moment	less than $1.5 \times 10^{-6}$ kg·m <sup>2</sup>	
Shaft load	Radial 15N; Axial 5N	
Allowed speed	≤6000 rpm	
Shell material	Aluminium alloy	
Weight	about 70g	

## 3.4 Environmental specification

Name	Parameter
Environmental temperature	Operating: -20~95°C
	Storage: -25~+95°C
Environmental humidity	Operating and storage:35~85%RH (Noncondensing)
Vibration	Amplitude 0.75mm ,5~55HZ,2h for X,Y,Z direction individually
Shock	490m/s <sup>2</sup> 11ms three times for X,Y,Z direction individually
Protection	IP50

## 4. Electrical Characteristics

### 4.1 Absolute Maximum Ratings

Symbol	Instructions	Minimum	Maximum	Unit
V <sub>CC</sub>	Supply Voltage	-0.3	+6.0	V
T <sub>STG</sub>	Storage Temperature	-20	+95	° C
T <sub>J</sub>	Junction Temperature	-	150	° C

### 4.2 Recommended electrical parameter

Symbol	Instruction	Minimum	Typical value	Maximum	Unit
V <sub>CC</sub>	Supply Voltage	4.75	5.0	5.5	V
I <sub>DD</sub>	Supply Current	-	-	120	mA
f <sub>BISS</sub> ①	BISS Communication clock frequency	-	-	10	MHz
	SSI Communication clock frequency	-	-	5.0	MHz
T <sub>a</sub>	Operating temperature	-20	-	+95	° C

① Pls refer to BiSS\_C and SSI standards.

5. Basic dimensions

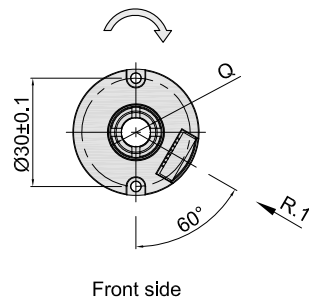
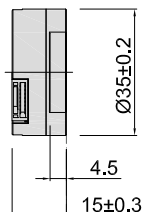
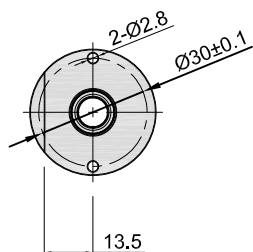

Front side

Q (Hollow shaft)
$\varnothing 6^{H7}_{0} (+0.015)$
$\varnothing 8^{H7}_{0} (+0.015)$

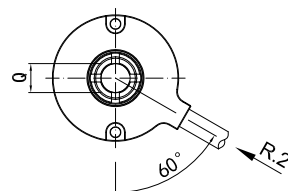

6. Specification for mounting shaft

Mounting screws
Inner hexagon bolt +flat washer Specification: M2.5*16 Material: stainless steel Quantity: 4

D(Motor shaft)
$\varnothing 6_{g6} (-0.005, -0.014)$
$\varnothing 8_{g6} (-0.005, -0.014)$

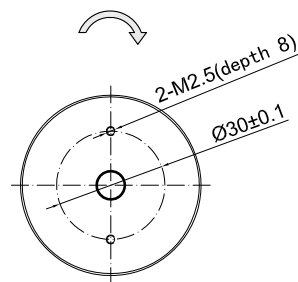
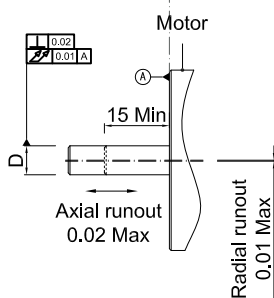

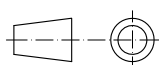

Unit: mm



- = Shaft rotation direction of the signal output
- R. 1 = Radial socket(8P SM08B-GHS-TB)
- R. 2 = Radial cable (standard length 1000)

### 7. Interface Definition

#### 7.1 Function and definition of socket pin (Radial socket)

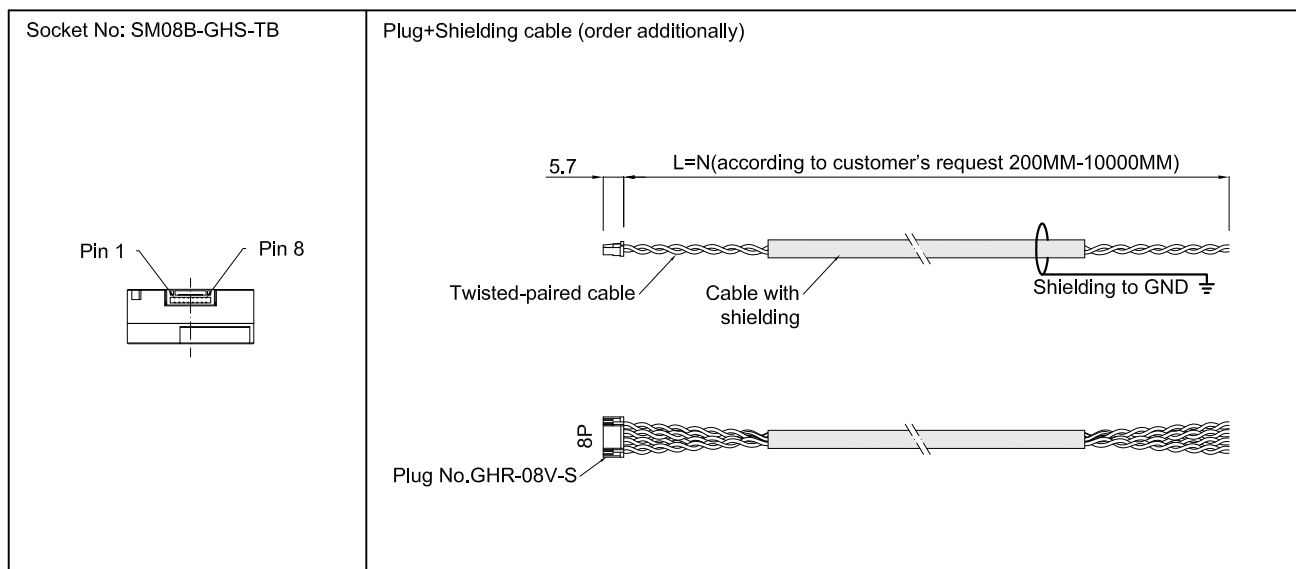

Pin No.	Signal		Function	Twisted-paired cable
	BISS_C ST	SSI ST		
Pin 1	Up	Up	Power positive	
Pin 2	Un	Un	Power negative	
Pin 3	SL-	DATA-	Data signal	
Pin 4	SL+	DATA+	Data signal	
Pin 5	MA-	CLOCK-	Clock signal	
Pin 6	MA+	CLOCK+	Clock signal	
Pin 7	-	-	-	
Pin 8	-	-	-	

#### 7.2 Socket definition



Unit: mm

7.3 Function and color definition (Radial cable)

Wire Color	Signal		Function	Twisted-paired cable
	BISS_C ST	SSI ST		
Red	Up	Up	Power positive	
Black	Un	Un	Power negative	
White	SL-	DATA-	Data signal	
White/black	SL+	DATA+	Data signal	
Green	MA-	CLOCK-	Clock signal	
Green/black	MA+	CLOCK+	Clock signal	

7.4 Radial cable schematic

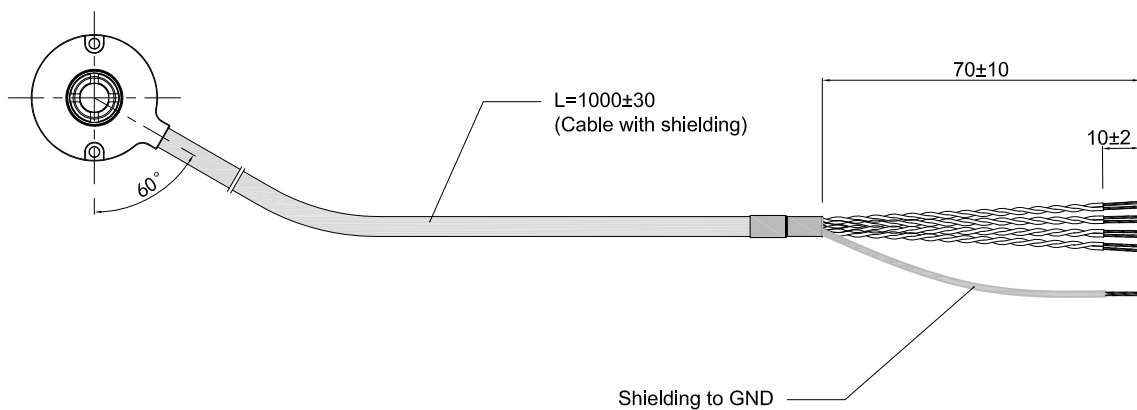

Unit: mm

7.5 Electrical Connection

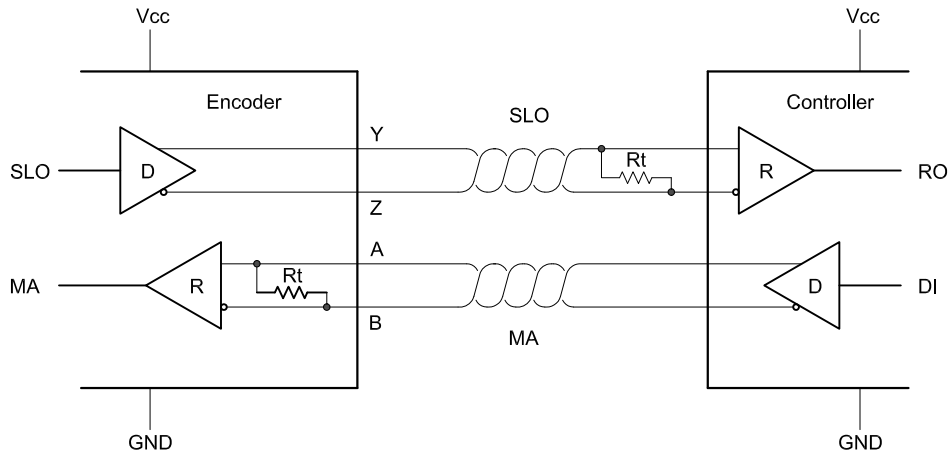

Figure 1: Point-to-point configuration

Note: Both the MA and SLQ lines are differential twisted-paired cable transmission, compatible with RS422.  
 The terminal resistor of the MA transmission line has been integrated inside the encoder.



7.6 BISS\_C Communication

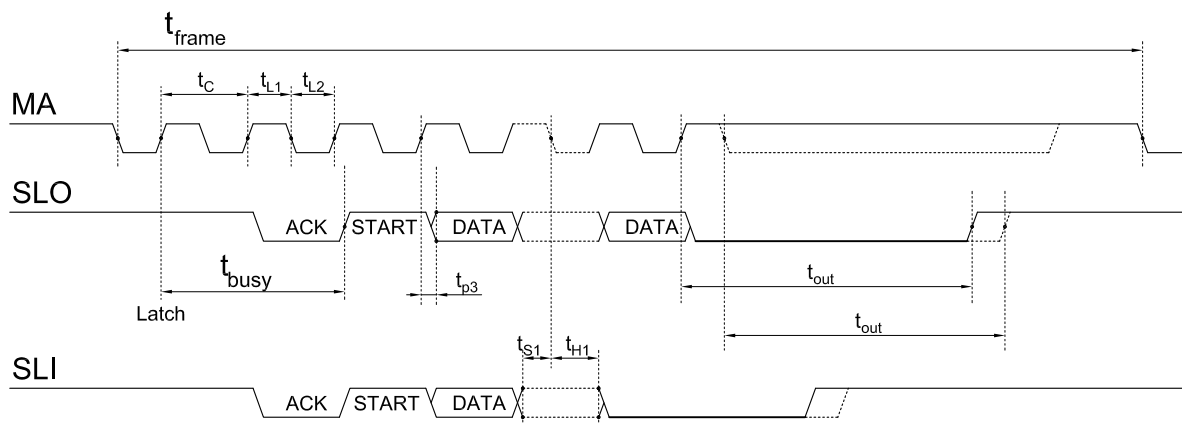

Figure 2: BISS-C Timing

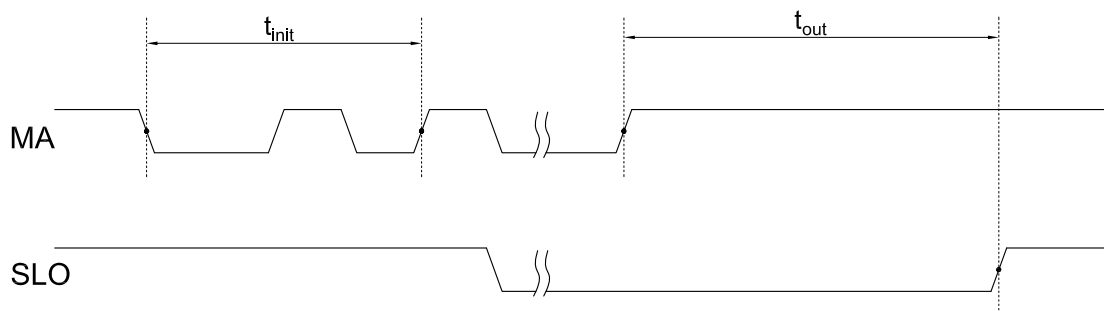

Figure 3: BISS-C (SSI) Slave Timeout Sequence

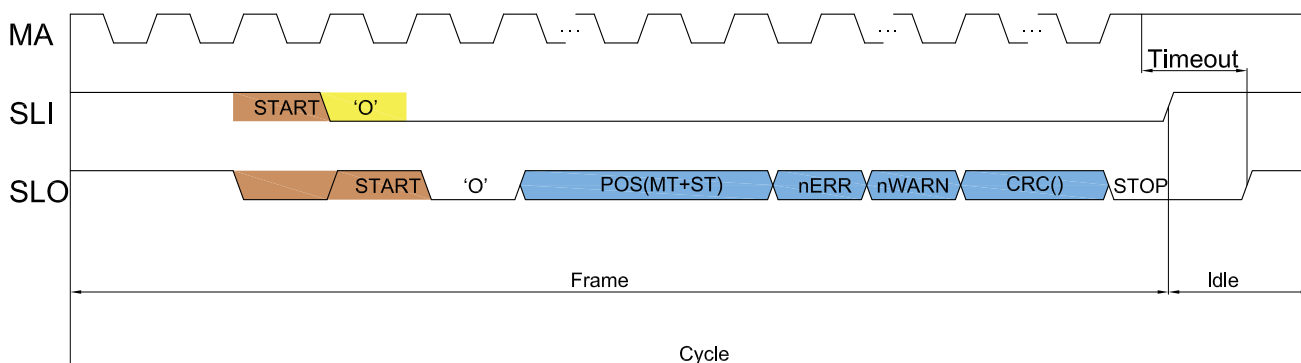

Figure 4: BISS Frame Structure

7.7 SSI Communication

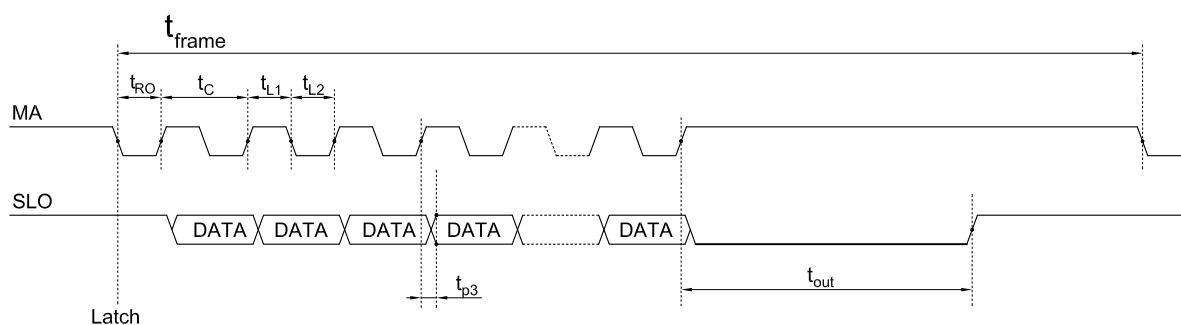

Figure 5: SSI Timing

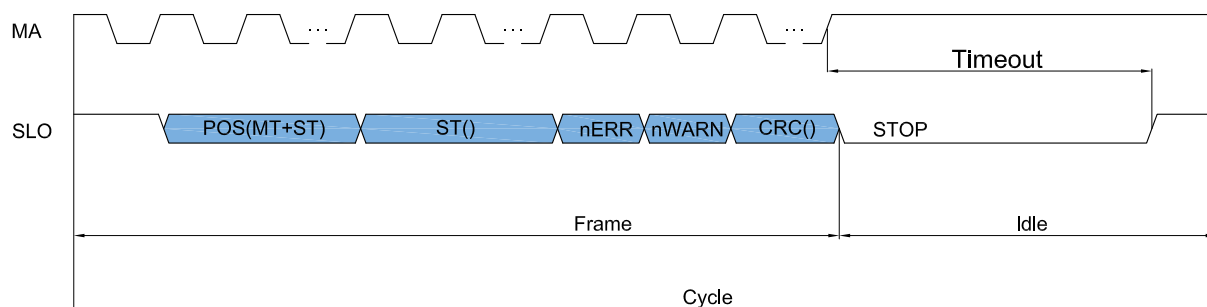

Figure 6: SSI Frame Structure

The frame is composed of frame structure and data to be transmitted. The sequence of data transmission first is MSB, error bit and alarm bit are low effective, cyclic redundancy check transmitted inverted. The specific data composition is shown in the below table:

Bits No.	Data	Instructions
[55:32]	MT[23:0]	Recording the accumulative number of the encoder running after power on, including directivity
[31:8]	ST[23:0]	Current data of absolute location
[7]	nERR	Error output, active low
[6]	nWARN	Warning output, active low
[5:0]	CRC[5:0]	Check bit CRC polynomial of 0x43 with a starting value of 0 (output at flip level)

### 8. Installation Steps

**First Step**

- a. Put the encoder(2) directly on the motor shaft and gently push it to the motor.
- b. Tighten four M2.5\*16 bolts (3) at the same time, but do not tighten them too tightly. When the shaft sleeve and the motor shaft are tightened, fasten the four bolts.

Note: Please refer to page 5 for the fit tolerances of the encoder bushing and the motor shaft.

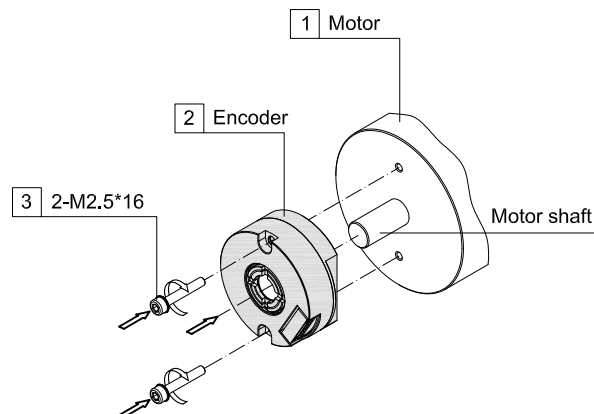

**Second Step**

Fix the spanner (A) on the slot of the encoder shaft sleeve, tighten the lock nut with the spanner (B). (the recommended tightening force is 7-10 N.m), and then tighten the four M2.5\*16 lock bolts (3).

**Note:**

To avoid loosening of the lock nut during use, which can cause displacement and slippage between the encoder shaft and motor shaft, it is necessary to apply thread adhesive to the threaded surface of the lock nut during installation and then tighten it.

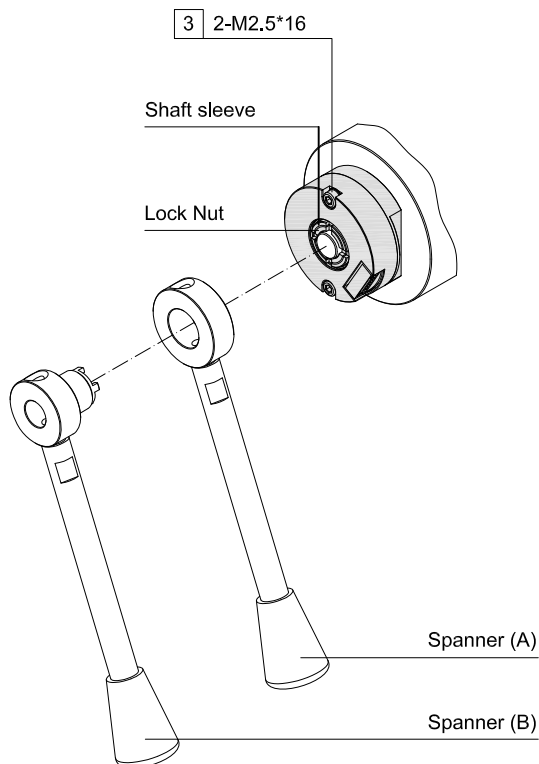

## 9. Caution

### 9.1 Caution for operation

- The working temperature shall not exceed the storage temperature.
- The working humidity shall not exceed the storage humidity.
- Do not use where the temperature changes dramatically and have fog.
- Do not close to corrosive and flammable gas.
- Keep away from dust, salt and metal powder.
- Keep away from places where you will use water, oil, or medicine.
- Undue vibration and shock will impact the encoder.

### 9.2 Caution for Installation

- Electrical components should not be subjected to excessive pressure, etc., and electrostatic assessment of the installation environment should be conducted.
- Do not close the cable of the motor power to the encoder.
- The FG wire of the motor and mechanical device should be grounded.
- The shielding wire must be effectively grounded since the shielding is not connected to the encoder.

### 9.3 Caution for wiring

- Use the encoder under the specified supply voltage. Please note that the supply voltage range may drop due to the wiring length.
- Do not put the encoder wiring and other power lines through the same duct, and do not use them by bundling in parallel.
- Please use twisted pair wires for the signal and power wires of encoder.
- Please do not apply excessive force to the cable of encoder, or it will may be damaged.